

THIS DRAWING IS UNPUBLISHED. RELEASED FOR PUBLICATION
 © COPYRIGHT - By - ALL RIGHTS RESERVED.

LOC	DIST	REVISIONS					
AF	50	P	LTR	DESCRIPTION	DATE	DWN	APVD
		S		REVISED PER ECR-12-013445	09NOV12	KH	PD

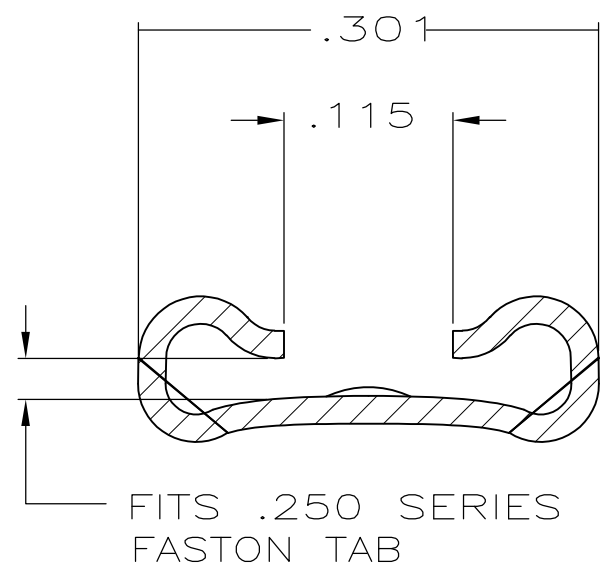
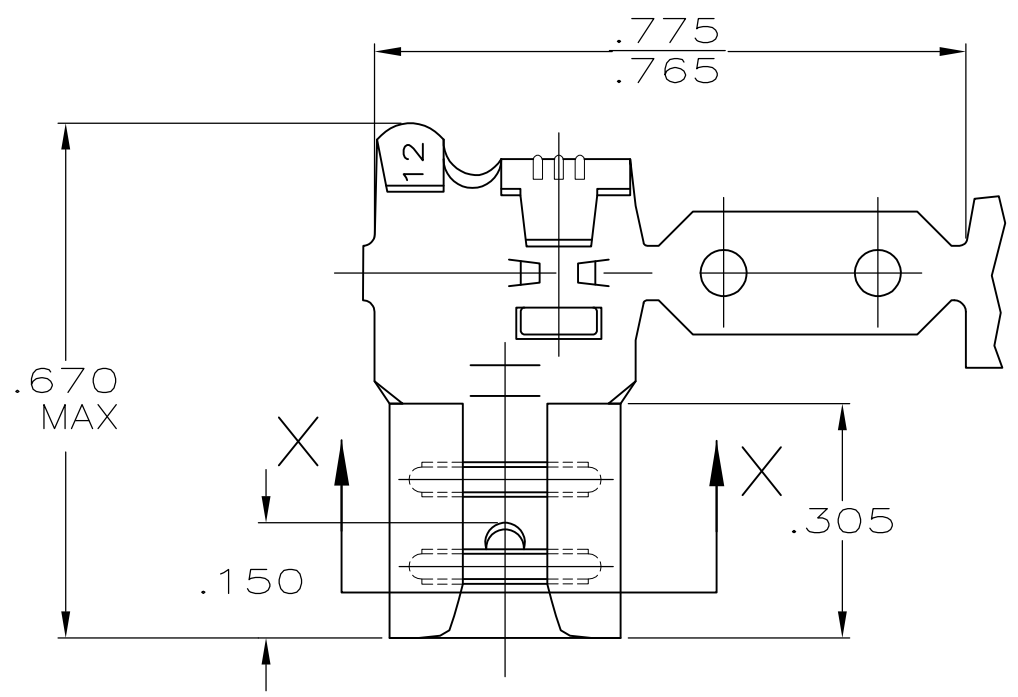

SECTION X-X
SCALE 8:1

- 1 CONTINUOUS STRIP ON REELS.
- 2 FOREIGN PRODUCTION ONLY.
- 4 MATING TAB THK IS .032±.001.
- 5 WIRE SIZE IS #18-#12 AWG
- 6 INSULATION RANGE IS .110-.210 DIA.
- 7 PRELIMINARY - NOT FOR PRODUCTION

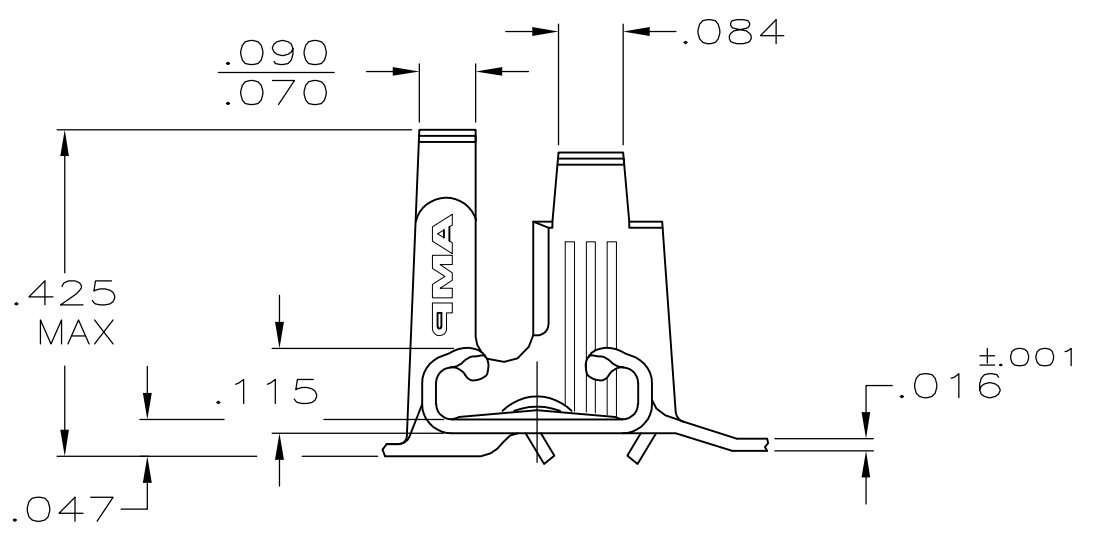

.000150 MIN NICKEL	T2 STEEL	7 42742-5
PRE-TIN	4M BRASS	2 42742-3
TIN	BRASS	42742-2
-	BRASS	42742-1
FINISH	MATERIAL	PART NO

THIS DRAWING IS A CONTROLLED DOCUMENT.		DWN	JR RUTH	1/23/91	STE TE Connectivity											
DIMENSIONS: INCHES		CHK	MS FEHER	1/24/93												
TOLERANCES UNLESS OTHERWISE SPECIFIED:		APVD	J GILLESPIE	1/24/93												
<table border="0"> <tr><td>0 PLC</td><td>± -</td></tr> <tr><td>1 PLC</td><td>± -</td></tr> <tr><td>2 PLC</td><td>± -</td></tr> <tr><td>3 PLC</td><td>± .015</td></tr> <tr><td>4 PLC</td><td>± -</td></tr> <tr><td>ANGLES</td><td>± -</td></tr> </table>		0 PLC	± -	1 PLC		± -	2 PLC	± -	3 PLC	± .015	4 PLC	± -	ANGLES	± -	NAME	
0 PLC	± -															
1 PLC	± -															
2 PLC	± -															
3 PLC	± .015															
4 PLC	± -															
ANGLES	± -															
MATERIAL	BRASS	FINISH	SEE TABLE	PRODUCT SPEC	-											
APPLICATION SPEC		-		SIZE	A3											
WEIGHT		-		CAGE CODE	00779											
CUSTOMER DRAWING		SCALE		4:1	SHEET											
				1	OF 1											
				REV	S											